

Technical Data Sheet

Stepless® Low Profile Clamps 192

Product Group 192



Connecting Technology

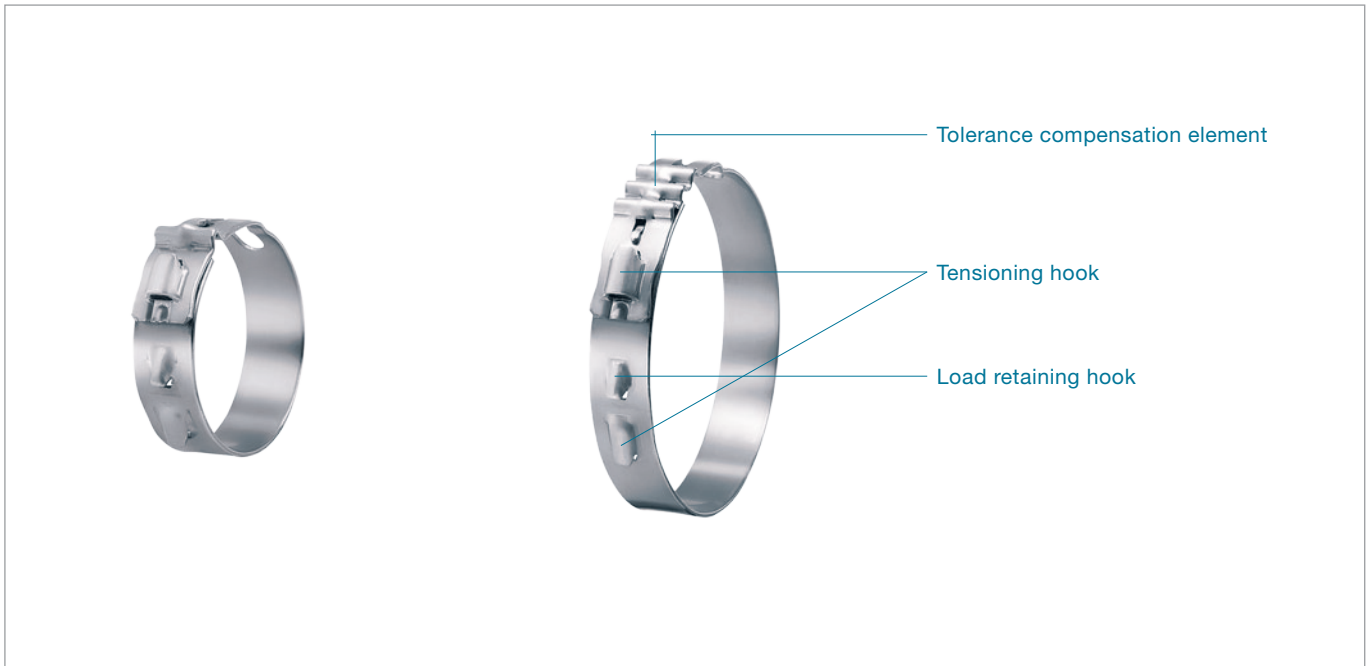

Tolerance compensation elements: allow for variations in component tolerances and temperature variations

360° Stepless®: uniform 360° compression or uniform surface pressure

Low installed height: minimum space requirement, low imbalance on rotating parts

Novel tensioning hook design: fast and simple installation, high radial force

Specially formed strip edges: reduced risk of damage to parts being clamped

Stepless® Low Profile Clamps 192 Product Group 192

Material

192 Stainless Steel, Material no. 1.4301/UNS S30400

Series

Nominal diameter	width x thickness	tol. element
19.5 – 60.0 mm	10.0 x 0.8 mm	1-wave
40.0 – 120.5 mm	10.0 x 0.8 mm	3-waves

Available in 0.5 mm diameter graduations on request.

Specific diameters can only be supplied when an appropriate minimum quantity is ordered.

OETIKER Stepless® Low Profile Clamps 192 are produced with 1-wave and 3-wave tolerance compensation elements. The dimensions of the material used within the standard range are determined taking into account the required radial force, the nature of the application and the need to maintain sealing and/or retaining properties under the specified conditions and environmental exposure. When selecting the clamp diameter, the dimensions of the mating components on which the clamp is to be installed must be accurately established to enable effective clamping performance. The durometer hardness of the soft material and desired compression are significant factors when calculating the appropriate clamp diameter.

Tensioning hooks

The tensioning hooks are the features used to close the Stepless® Low Profile Clamp 192. An OETIKER closing tool engages in both tensioning features, and tool movement reduces the clamp diameter until the internal cavity of the tensioning hook on the overlapping band fully engages in the load-retaining hook.

The diameter reduction of the clamp is substantially proportional to the closing travel, but subject to slight variations, depending on the degree to which tolerance compensation is required and the required radial force. The theoretical maximum reduction in diameter is given by the formula:

$$\text{Max. diameter reduction} = \frac{\text{closing travel}}{\pi}$$

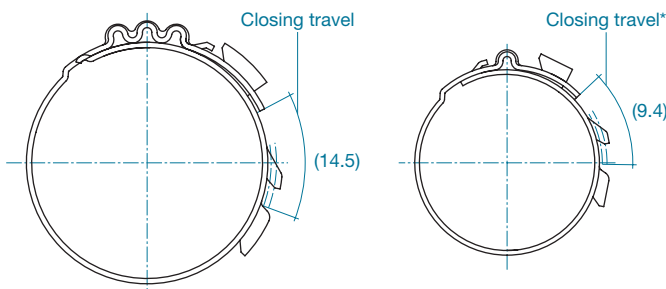

* Optionally available with enlarged as-supplied diameter (greater closing travel)

Tolerance compensation

The tolerance compensation waves are activated when the compressed diameter of the application is greater than the nominal diameter of the clamp. When the resistance against the clamp exceeds the strength of the formed convolutes, elongation occurs to enable successful engagement of the tensioning and retaining hooks.

The flexible effect of the convolutes has the potential to accommodate diameter changes due to the effects of temperature changes and vibration.

As a rule, the nominal diameter of an OETIKER Stepless® Low Profile Clamp 192 should be selected to enable the optimum hose or seal compression at the minimum assembly diameter. In the event of a maximum assembly installation, the convolutes must be capable of elongating to absorb the diameter increase while maintaining the ability to achieve the interlock engagement, taking into account the maximum permitted pincer force and the amount of elongation the convolutes can withstand.

The capability of the tolerance-compensation element, the properties and dimensional tolerance of the materials being joined all directly affect the overall functionality of the connection.

Assembly Recommendations

These clamps can be installed using manual pincers especially developed for this clamp design or, alternatively, pneumatic pincers for high volume installations. To close a clamp, the pincer jaws must be engaged within both tensioning hooks. By operating the pneumatic tool or closing the manual pincer, the simultaneous movement of the two tensioning hooks reduces the diameter of the Stepless® Low Profile Clamp 192 until the effective closed diameter is achieved. The geometry of the Stepless® Low Profile Clamp 192 is such that, on reaching this position, the internal contour of the tensioning hook on the overlapping end of the clamp engages automatically in the load retaining hook.

The surface pressure generated depends on the selection criteria, especially the diameter and materials of the parts being clamped. Sealing performance is derived mainly from the restoring force of the compressed elastic material combined with tension from the tolerance-compensation elements.

Complete process monitoring, including 100% documentation is available using the "Electronically Controlled Pneumatic Power Tool OETIKER ELK 01".

Rotation diameter

The rotation diameter (RD) of an assembled clamp can be critical design information for applications that rotate in close proximity to adjacent components.

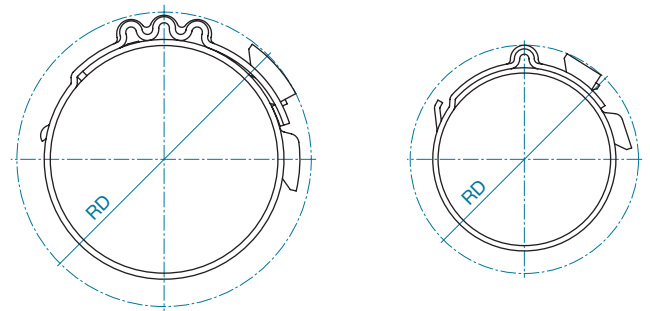

Accurate Information regarding rotation diameter can be provided on request.

Note on ordering

In contrast to ear clamps, Stepless® Low Profile Clamps are identified with the nominal closed diameter, e.g. 195 for a closed and installed diameter of 19.5 mm.

Material dimensions	Manual pincer*	Recommended pneumatic pincer**
10.0 x 0.8 mm	14100134	HO 5000 EL/HO 7000 EL

* 14100134 Manual pincer for Stepless® Low Profile Clamps 192.

** With appropriate pincer head and closing force setting.

Please provide us with appropriate sample parts and comprehensive information about the application.

Order information

Item No. Ø upon Ø nominal,
 delivery (mm) closed (mm)*

Tolerance compensation element 1-wave
Band width 10 mm, thickness 0.8 mm

19200686	22.5	19.5
19200684	23	20
19200685	23.5	20.5
19200688	24	21
19200733	24.5	21.5
19200734	25	22
19200244	25.5	22.5
19200245	26	23
19200255	26.5	23.5
19200263	27	24
19200368	27.5	24.5
19200369	28	25
19200370	28.5	25.5
19200371	29	26
19200372	29.5	26.5
19200253	30	27
19200322	30.5	27.5
19200373	31	28
19200374	31.5	28.5
19200268	32	29
19200375	32.5	29.5
19200376	33	30
19200377	33.5	30.5
19200378	34	31
19200379	34.5	31.5
19200380	35	32
19200381	35.5	32.5
19200333	36	33
19200335	36.5	33.5
19200382	37	34
19200383	37.5	34.5
19200332	38	35
19200384	38.5	35.5
19200385	39	36
19200386	39.5	36.5
19200358	40	37
19200387	40.5	37.5
19200388	41	38
19200389	41.5	38.5
19200390	42	39
19200391	42.5	39.5
19200392	43	40
19200393	43.5	40.5
19200394	44	41
19200395	44.5	41.5
19200396	45	42
19200397	45.5	42.5
19200398	46	43
19200399	46.5	43.5

Item No. Ø upon Ø nominal,
 delivery (mm) closed (mm)*

Tolerance compensation element 1-wave
Band width 10 mm, thickness 0.8 mm

19200400	47	44
19200401	47.5	44.5
19200402	48	45
19200403	48.5	45.5
19200404	49	46
19200405	49.5	46.5
19200406	50	47
19200407	50.5	47.5
19200408	51	48
19200409	51.5	48.5
19200410	52	49
19200411	52.5	49.5
19200412	53	50
19200413	53.5	50.5
19200414	54	51
19200415	54.5	51.5
19200416	55	52
19200417	55.5	52.5
19200418	56	53
19200419	56.5	53.5
19200420	57	54
19200421	57.5	54.5
19200422	58	55
19200423	58.5	55.5
19200424	59	56
19200425	59.5	56.5
19200426	60	57
19200427	60.5	57.5
19200428	61	58
19200429	61.5	58.5
19200430	62	59
19200431	62.5	59.5
19200432	63	60

Optionally available with enlarged as
supplied diameter (greater closing travel).

Item No. Ø upon Ø nominal,
 delivery (mm) closed (mm)*

Tolerance compensation element 3-waves
Band width 10 mm, thickness 0.8 mm

19200454	44.5	40
19200455	45	40.5
19200350	45.5	41
19200352	46	41.5
19200456	46.5	42
19200457	47	42.5
19200458	47.5	43
19200459	48	43.5
19200460	48.5	44
19200461	49	44.5
19200462	49.5	45
19200463	50	45.5
19200464	50.5	46
19200465	51	46.5
19200466	51.5	47
19200467	52	47.5
19200468	52.5	48
19200469	53	48.5
19200470	53.5	49
19200471	54	49.5
19200472	54.5	50
19200473	55	50.5
19200474	55.5	51
19200339	56	51.5
19200340	56.5	52
19200475	57	52.5
19200476	57.5	53
19200477	58	53.5
19200478	58.5	54
19200479	59	54.5
19200480	59.5	55
19200481	60	55.5
19200482	60.5	56
19200483	61	56.5
19200484	61.5	57
19200485	62	57.5
19200486	62.5	58
19200487	63	58.5
19200488	63.5	59
19200489	64	59.5
19200490	64.5	60
19200491	65	60.5
19200492	65.5	61
19200493	66	61.5
19200494	66.5	62
19200495	67	62.5
19200496	67.5	63
19200341	68	63.5
19200342	68.5	64

Order information

Item No. Ø upon Ø nominal,
 delivery (mm) closed (mm)*

Item No. Ø upon Ø nominal,
 delivery (mm) closed (mm)*

Item No. Ø upon Ø nominal,
 delivery (mm) closed (mm)*

Tolerance compensation element 3-waves
Band width 10 mm, thickness 0.8 mm

Tolerance compensation element 3-waves
Band width 10 mm, thickness 0.8 mm

Tolerance compensation element 3-waves
Band width 10 mm, thickness 0.8 mm

19200497	69	64.5
19200498	69.5	65
19200499	70	65.5
19200500	70.5	66
19200501	71	66.5
19200502	71.5	67
19200503	72	67.5
19200504	72.5	68
19200505	73	68.5
19200506	73.5	69
19200507	74	69.5
19200508	74.5	70
19200509	75	70.5
19200510	75.5	71
19200511	76	71.5
19200512	76.5	72
19200513	77	72.5
19200514	77.5	73
19200515	78	73.5
19200516	78.5	74
19200517	79	74.5
19200518	79.5	75
19200519	80	75.5
19200520	80.5	76
19200521	81	76.5
19200522	81.5	77
19200523	82	77.5
19200524	82.5	78
19200525	83	78.5
19200526	83.5	79
19200527	84	79.5
19200528	84.5	80
19200529	85	80.5
19200530	85.5	81
19200531	86	81.5
19200532	86.5	82
19200533	87	82.5
19200534	87.5	83
19200535	88	83.5
19200536	88.5	84
19200537	89	84.5
19200538	89.5	85
19200539	90	85.5
19200540	90.5	86
19200541	91	86.5
19200542	91.5	87
19200543	92	87.5
19200544	92.5	88
19200545	93	88.5

19200546	93.5	89
19200547	94	89.5
19200548	94.5	90
19200362	95	90.5
19200549	95.5	91
19200550	96	91.5
19200551	96.5	92
19200552	97	92.5
19200553	97.5	93
19200554	98	93.5
19200555	98.5	94
19200556	99	94.5
19200557	99.5	95
19200558	100	95.5
19200559	100.5	96
19200560	101	96.5
19200561	101.5	97
19200562	102	97.5
19200563	102.5	98
19200564	103	98.5
19200565	103.5	99
19200566	104	99.5
19200567	104.5	100
19200568	105	100.5
19200569	105.5	101
19200570	106	101.5
19200571	106.5	102
19200572	107	102.5
19200573	107.5	103
19200343	108	103.5
19200348	108.5	104
19200574	109	104.5
19200575	109.5	105
19200576	110	105.5
19200577	110.5	106
19200578	111	106.5
19200579	111.5	107
19200580	112	107.5
19200581	112.5	108
19200582	113	108.5
19200583	113.5	109
19200584	114	109.5
19200585	114.5	110
19200586	115	110.5
19200587	115.5	111
19200588	116	111.5
19200589	116.5	112
19200590	117	112.5
19200591	117.5	113

19200592	118	113.5
19200593	118.5	114
19200594	119	114.5
19200595	119.5	115
19200596	120	115.5
19200597	120.5	116
19200598	121	116.5
19200599	121.5	117
19200600	122	117.5
19200601	122.5	118
19200602	123	118.5
19200603	123.5	119
19200604	124	119.5
19200605	124.5	120
19200606	125	120.5

* Without affecting the tolerance-compensation element (free state).

The OETIKER Group: www.oetiker.com

Headquarters Switzerland
Hans Oetiker AG
Maschinen- und Apparatefabrik
Oberdorfstrasse 21
CH-8812 Horgen (Zürich)
T +41 44 728 55 55
F +41 44 728 55 15
info@ch.oetiker.com

Austria
Hans Oetiker
Maschinen- und Apparatebau
Ges.m.b.H.
Eduard-Klinger-Strasse 19
A-3423 St. Andrä-Wördern
T +43 2242 33 994-0
F +43 2242 33 997
info@at.oetiker.com

Belgium
Oetiker Belgium N.V./S.A.
Maaltecenter – Blok “G”
Derbystraat 301
9051 Gent/St. Denijs-Westrem
T +32 9 252 25 55
F +32 9 252 25 56
info@be.oetiker.com

Canada
Oetiker Limited
203 Dufferin Street South
P. O. Box 5500
Alliston, Ontario L9R 1W7
T +1 705 435 4394
info@ca.oetiker.com

P. R. China
Oetiker Industries (Tianjin) Ltd.
10 Shuangchenzhong Road
Beichen High Tech Industrial Park
Tianjin 300400
T +86 22 2697 1183
F +86 22 2697 1380
info@cn.oetiker.com

Czech Republic
Hans Oetiker spol. s r. o.
Videnska 116
CZ-37833 Nová Bystrice
T +420 384 386513
F +420 384 386386
info@cz.oetiker.com

France
Oetiker Sarl
9, rue Jean Moulin
ZA du Pré Fusé
F-77348 Pontault-Combault Cedex
T +33 1 60 29 90 39
F +33 1 64 40 90 23
info@fr.oetiker.com

Germany
Hans Oetiker
Metallwaren- & Apparatefabrik GmbH
Üsenbergerstrasse 13
D-79346 Endingen a. K.
T +49 76 42 6 84-0
F +49 76 42 6 84-125
info@de.oetiker.com

Kurt Allert GmbH & Co. KG
Postfach 1160
Austrasse 36
D-78727 Oberndorf a. N.
T +49 74 23 87 70-0
F +49 7 4 23 87 70-87
info@allert.oetiker.com

Hong Kong
Oetiker Far East Limited
2210 Tuen Mun Central Square
22 Hoi Wing Road
Tuen Mun NT
T +852 2459 8211
F +852 2459 8322
info@hk.oetiker.com

Hungary
Oetiker Hungaria KFT
Vasvári P. U. 11
H-9800 Vasvár
T +36 94 370 630
F +36 94 370 533
info@hu.oetiker.com

India
Oetiker India Private Ltd.
N-14, Additional Patalganga
Industrial Area
Village Chavane, Khalapur
Rasayani 410 220
Dist. Raigad
T +91 2192 250107-12
F +91 2192 250105
info@in.oetiker.com

Japan
Oetiker Japan Co. Ltd.
Kaneko Bldg. A
5-3-5 Nakamachi-dai, Tsuzuki-ku
Yokohama 224-0041
T +81 45 949 3151
F +81 45 949 3152
info@jp.oetiker.com

Netherlands
Oetiker Benelux B.V.
Hertzstraat 38
NL-6716 BT Ede
T +31 318 63 71 71
F +31 318 63 34 89
info@nl.oetiker.com

Spain
Oetiker España, S. A.
Pol. Ind. Las Salinas
C/Puente, 18
E-11500 El Puerto
de Santa María (Cádiz)
T +34 956 86 04 40
F +34 956 87 17 07
info@es.oetiker.com

United Kingdom
Oetiker UK Limited
Foundry Close
GB-Horsham, Sussex RH13 5PX
T +44 1403 26 04 78
F +44 1403 24 06 90
info@uk.oetiker.com

USA
Oetiker, Inc.
6317 Euclid Street
Marlette, Michigan 48453-0217
T +1 989 635 3621
F +1 989 635 2157
info@us.oetiker.com